

THIS COPY IS PROVIDED ON A RESTRICTED BASIS AND IS NOT TO BE USED IN ANY WAY DETRIMENTAL TO THE INTERESTS OF PANDUIT CORP.

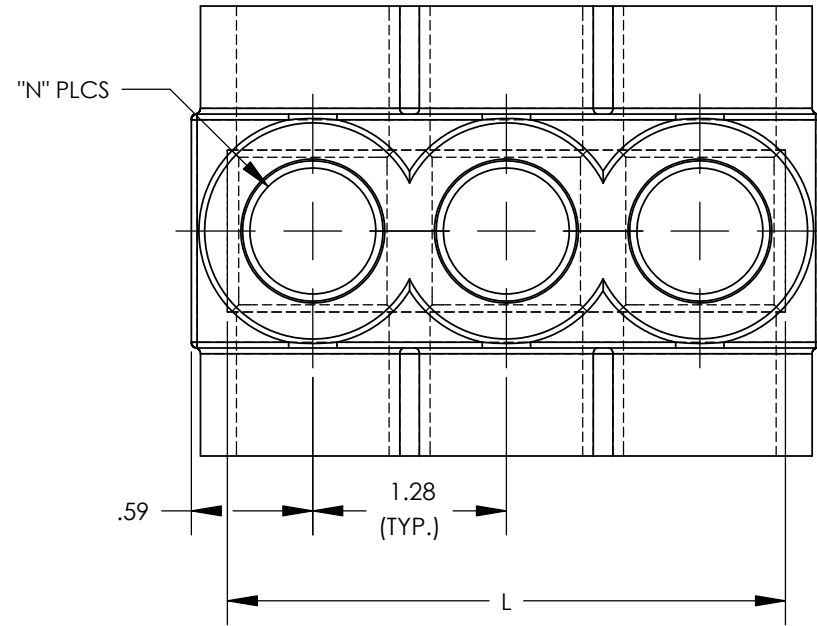

THREE PORT CONNECTOR BLOCK SHOWN WITH PLASTIC CLOSURE PLUGS REMOVED. SEE TABLE FOR DIMENSIONS OF PARTS WITH ADDITIONAL PORTS

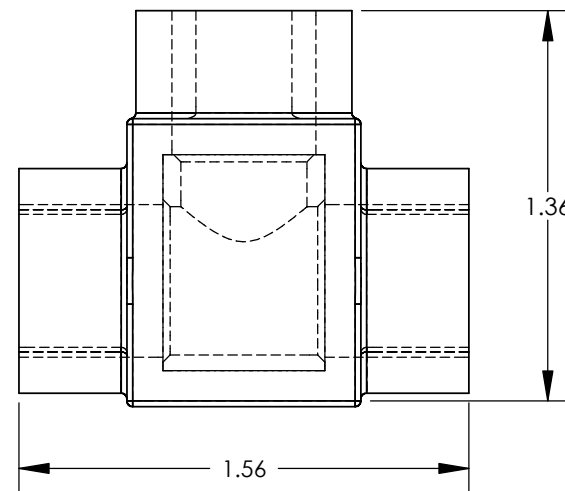
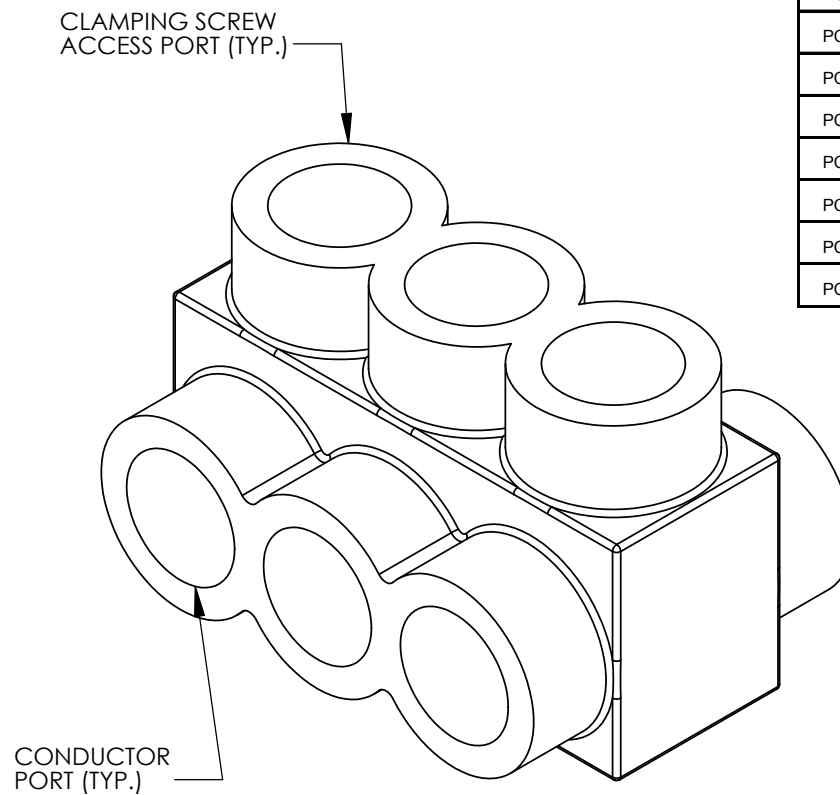
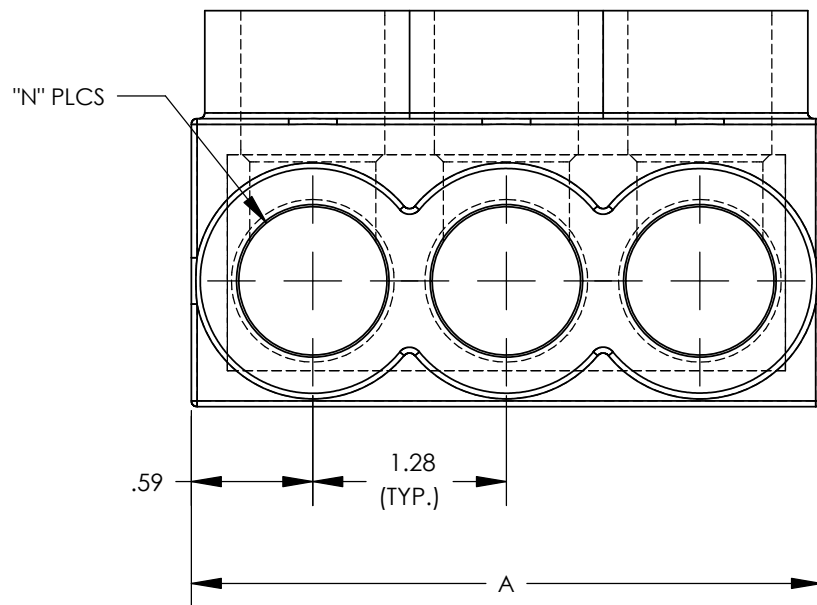

PANDUIT FINISHED GOODS P/N	CONDUCTOR RANGE	HEX KEY	SCREW QTY.	CAP (SCREW PORT) QTY.	CAP (WIRE PORT) QTY.	A	L	N	TIGHTENING TORQUE
PCSB600-2-4Y	600 kcmil - #6 STR	3/8	2	2	4	2.72	2.469	2	375 in/lb
PCSB600-3-2Y		3/8	3	3	6	4.00	3.750	3	
PCSB600-4-2Y		3/8	4	4	8	5.28	5.031	4	
PCSB600-5-2		3/8	5	5	10	6.56	6.312	5	
PCSB600-6-2Y		3/8	6	6	12	7.84	7.593	6	
PCSB600-8-2Y		3/8	8	8	16	10.41	10.155	8	
PCSB600-10-1Y		3/8	10	10	20	12.97	12.717	10	
PCSB600-12-1Y		3/8	12	12	24	15.53	15.279	12	
PCSB600-14-1Y		3/8	14	14	28	18.09	17.841	14	

NOTES:

- UL486A-UL486B LISTED, DUAL RATED CU9AL FOR ALUMINUM OR COPPER CONDUCTORS. MEETS OR EXCEEDS ANSI C119.4
- SEE TABLE FOR WIRE RANGE.
- STRIP LENGTH: 1.06 +.06/-0
- FOR TIGHTENING TORQUE SEE TABLE
- VOLTAGE RATING: 600 V. MAX. BUILDING WIRE, 1000 V. MAX. IN SIGNS & FIXTURES.
- TEMPERATURE RATING: 90 °C (CU9AL).
- CONNECTOR BLOCK BODY ARE MADE FROM ALUMINUM. CONDUCTOR PORTS IN CONNECTOR BLOCK ARE PREFILLED WITH AN OXIDE-INHIBITING COMPOUND.
- CONNECTOR TO INCLUDE TIN PLATED ALUMINUM CLAMPING SCREWS FOR EACH CONDUCTOR PORT.
- INSULATION MATERIAL IS CLEAR PVC.
- CLAMPING SCREW ACCESS PORTS AND ALL WIRE ENTRY PORTS ARE PROVIDED WITH REMOVABLE PLASTIC CLOSURE PLUGS.
- ALL DIMENSIONS SHOWN ARE NOMINAL.
- ONLY ONE CONDUCTOR PER PORT ALLOWED.
- PACKAGE QTY: -12 = 12 PCS.
-6 = 6 PCS.
-4 = 4 PCS.
- THIS PART IS RoHS COMPLIANT.



PANDUIT CORP. TINLEY PARK, ILLINOIS											
MULTI-TAP INSULATED CONNECTORS PCSB600 SERIES											
UNLESS OTHERWISE SPECIFIED DIMENSIONAL TOLERANCES ARE: (.X) ± (.XXX) ± (.XX) ± ANGLES ±							UNLESS OTHERWISE SPECIFIED, ALL DIMENSIONS ARE GIVEN IN INCHES, THIRD ANGLE PROJECTION				
05	3/10	JHNU	JHNU	REVISED DIMENSION: .59 WAS .42 REVISED DIMENSION: 1.28 WAS .67							
04	2/10	JHNU	JHNU	REVISED WIRE RANGE: 600 kcmil - #6 STR was 600 kcmil - #4 STR							
03	11/09	JHNU	JHNU	REVISED NOTE 3: 1.06 WAS .56 ADDED HEX KEY SIZE TO TABLE							
REV	DATE	BY	CHK	DESCRIPTION	ECN	CUST	QA	APP	CHK'D RLS		
							DRAWN BY MS		MAT'L:	SCALE 1.5:1	
							DATE 08/99		SEE NOTE 1 ABOVE	DRAWING NO / CAD FILE	DWG B SIZE
										C41530_05	